

# Square flange bearing units

## SUCFN/T - SHCFN/T



### Waterproof housing

### Grub screws or eccentric collar shaft locking

### PA FV polyamide housing

High mechanical and heat resistance. Proof to dust, humidity, washouts, steam, average aggressive chemical agents.

### PP FV polypropylene housing

Proof to highly aggressive chemical agents. Inferior loading ability.

### Solid flange bearings

Closed surface structure, ideal for sanitation.

### Material

#### PA FV polyamide housing

- Housing in reinforced polyamide PA FV resin (black)
- Protection cover in polypropylene PP (orange)
- Seal and O-Ring in NBR rubber (black)
- Ball type nickel plated brass greasing nipple
- Reinforcing bushings on mounting holes and washers in stainless steel AISI 304

#### PP FV polypropylene housing

- Housing in reinforced polypropylene PP FV resin (white)
- Protection cover in polypropylene PP (orange)
- Seal and O-Ring in NBR rubber (black).  
On request supplied in Viton rubber (brown).  
Viton material offers high resistance to chemical agents
- Ball type stainless steel AISI 316 greasing nipple
- Reinforcing bushings on mounting holes and washers in stainless steel AISI 316.

### Continuous operating temperature

in air: - 20 to + 60°C.

### Maximum allowed misalignment: 2°.

### Bearing



- Type A (grub screws shaft locking)
- Type D (eccentric collar shaft locking)
- Chrome alloy steel
- Superagriseal unit
- Prelubricated with lithium / calcium grease
- Can be relubricated.



### • Series SUCFN/T • Type A Grub screws shaft locking

### • Series SHCFN/T • Type D Eccentric collar shaft locking

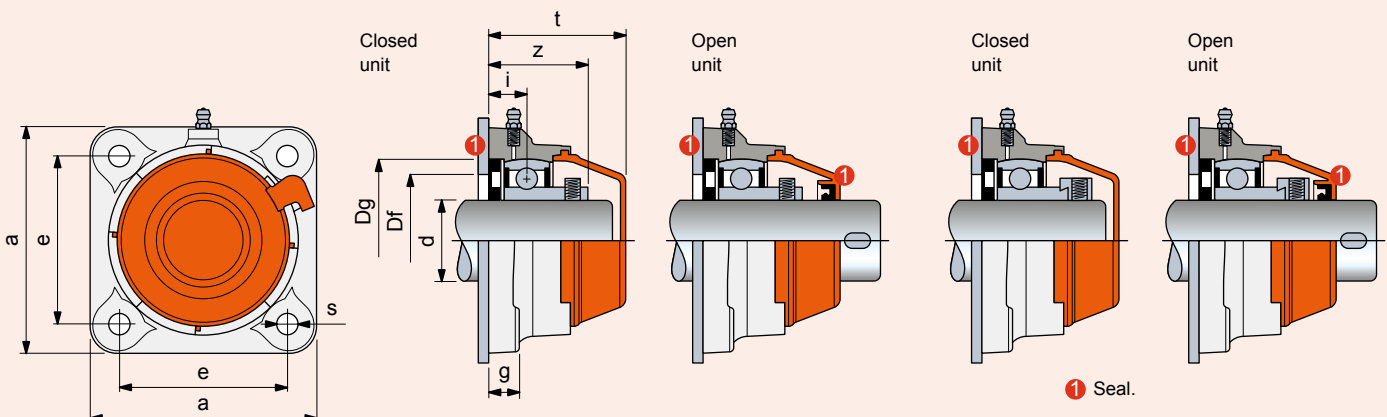

dia. d mm	Series	Housing material		Dimensions in mm										Bore in frame <sup>1)</sup> Df		Bearing	Weight Kg	Spare parts Cover orange <b>Code</b>	
		Polyamide PA FV Solid Flange (black) Cover (orange)	Polypropylene PP FV Solid Flange (white) Cover (orange)	e	a	s	g	i	z	t	Dg	max.	min.						
<b>Grub screws shaft locking • Closed unit</b>																			
40*	SUCFN 208 T	<b>637773</b>	<b>637853</b>	83	110	11	15	19	44	67	80	78	65	Type A	0,82	630443			
<b>Grub screws shaft locking • Open unit</b>																			
40*	SUCFN 208 T	<b>637783</b>	<b>637863</b>	83	110	11	15	19	44	67	80	78	65	Type A	0,82	630473			
<b>Eccentric collar shaft locking • Closed unit</b>																			
40*	SHCFN 208 T	<b>637793</b>	<b>637873</b>	83	110	11	15	19	51,7	67	80	78	65	Type D	1,01	630443			
<b>Eccentric collar shaft locking • Open unit</b>																			
40*	SHCFN 208 T	<b>637803</b>	<b>637883</b>	83	110	11	15	19	51,7	67	80	78	65	Type D	1,01	630473			

**Item code for order = B0000 + Code**

\* = Version with special fixing holes.

<sup>1)</sup> = Dimensions Df max / Df min must be respected to ensure positive retention of the seals and to allow air bleeding during lubrication.

Packaging: 6 pieces.

# Square flange bearing units

## SUCFN/TL - SHCFN/TL

**LIFE LUBRICATED**



**Dry use recommended**



### Life lubricated

The ball-bearings are pre-lubricated with a special grease keeping the bearing for its whole life. No need for re-lubrication (see page B78 to calculate the grease life).

### Grub screws or eccentric collar shaft locking

### PA FV polyamide housing

High mechanical and heat resistance. Proof to dust, humidity, washouts, steam, average aggressive chemical agents.

### Solid flange bearings

Closed surface structure, ideal for sanitation.

### Material

#### PA FV polyamide housing

- Housing in reinforced polyamide PA FV resin (black)
- Protection cover in polypropylene PP (orange)
- Seal and O-Ring in NBR rubber (black)
- Reinforcing bushings on mounting holes and washers in stainless steel AISI 304.

### Continuous operating temperature

in air: -20 to +60°C.

### Maximum allowed misalignment: 2°.

### Bearing



- Type A (grub screws shaft locking)
- Type D (eccentric collar shaft locking)
- Chrome alloy steel
- Superagriseal unit
- Prelubricated with lithium / calcium grease, no need for re-lubrication.



### • Series SUCFN/TL • Type A Grub screws shaft locking

### • Series SHCFN/TL • Type D Eccentric collar shaft locking

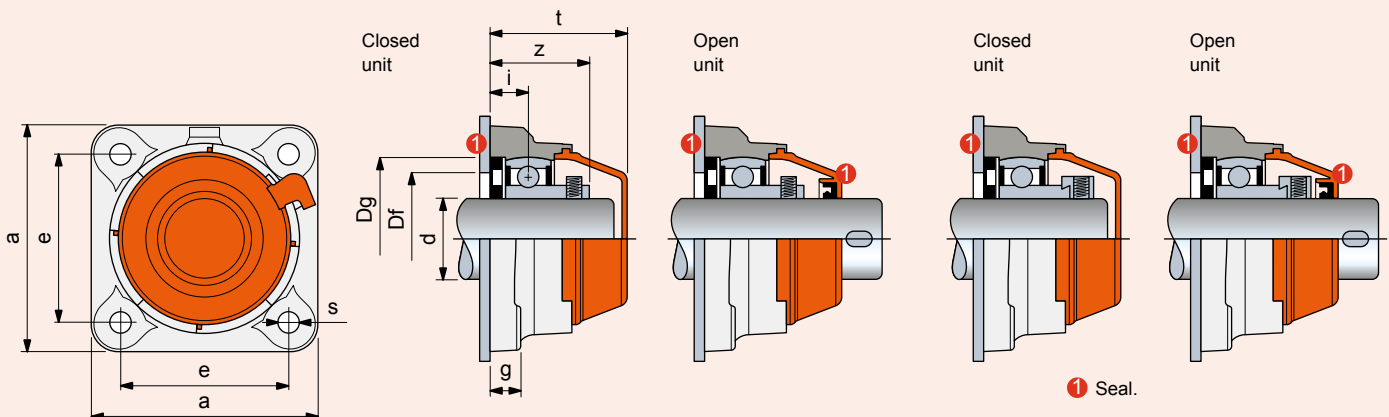

1 Seal.

# SUCFN/TL - SHCFN/TL

dia. d mm	Series	Housing material	Dimensions in mm										Bore in frame Df		Bearing	Weight Kg	Spare parts Cover orange
		Polyamide PA FV Solid Flange (black) Cover (orange)	e	a	s	g	i	z	t	Dg	max.	min.	Code				
<b>Grub screws shaft locking • Closed unit</b>																	
40*	SUCFN 208 TL	637773L	83	110	11	15	19	44	67	80	78	65	Type A	0,82	630443		
<b>Grub screws shaft locking • Open unit</b>																	
40*	SUCFN 208 TL	637783L	83	110	11	15	19	44	67	80	78	65	Type A	0,82	630473		
<b>Eccentric collar shaft locking • Closed unit</b>																	
40*	SHCFN 208 TL	637793L	83	110	11	15	19	51,7	67	80	78	65	Type D	1,01	630443		
<b>Eccentric collar shaft locking • Open unit</b>																	
40*	SHCFN 208 TL	637803L	83	110	11	15	19	51,7	67	80	78	65	Type D	1,01	630473		

**Item code for order = B0000 + Code**

\* = Version with special fixing holes.

Packaging: 6 pieces.

# Square flange bearing units

UCFN/C - SUCFN/C - HCFN/C - SHCFN/C



## Waterproof housing

## Grub screws or eccentric collar shaft locking

## PA FV polyamide housing

High mechanical and heat resistance. Proof to dust, humidity, washouts, steam, average aggressive chemical agents.

## PP FV polypropylene housing

Proof to highly aggressive chemical agents. Inferior loading ability.

## Solid flange bearings

Closed surface structure, ideal for sanitation.

### Material

#### PA FV polyamide housing

- Housing in reinforced polyamide PA FV resin (black)
- Protection cover in polypropylene PP (orange)
- Seal and O-Ring in NBR rubber (black)
- Ball type nickel plated brass greasing nipple
- Reinforcing bushings on mounting holes and washers in stainless steel AISI 304

#### PP FV polypropylene housing

- Housing in reinforced polypropylene PP FV resin (white)
- Protection cover in polypropylene PP (orange)
- Seal and O-Ring in NBR rubber (black).  
On request supplied in Viton rubber (brown).  
Viton material offers high resistance to chemical agents
- Ball type stainless steel AISI 316 greasing nipple
- Reinforcing bushings on mounting holes and washers in stainless steel AISI 316.

### Continuous operating temperature

in air: - 20 to + 60°C.

### Maximum allowed misalignment: 2°.

### Bearing



- Type A (grub screws shaft locking)
- Type D (eccentric collar shaft locking)
- Chrome alloy steel
- Superagriseal unit
- Prelubricated with lithium / calcium grease
- Can be relubricated.

### • Series UCFN/C • Type A Grub screws shaft locking

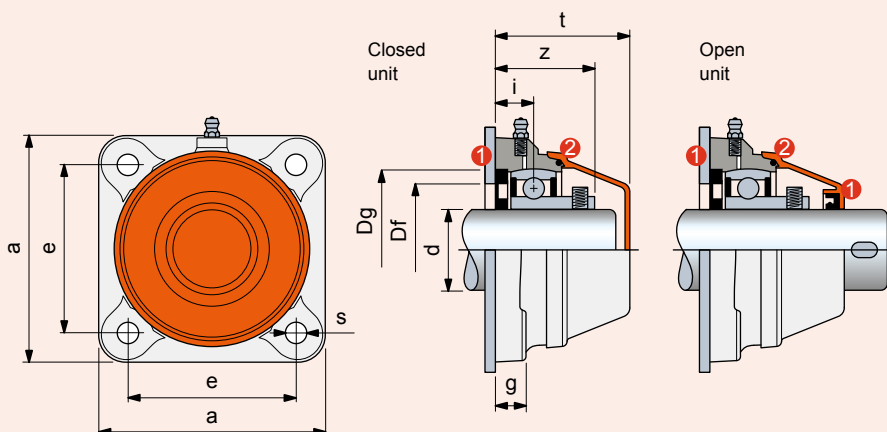

### • Series HCFN/C • Type D Eccentric collar shaft locking

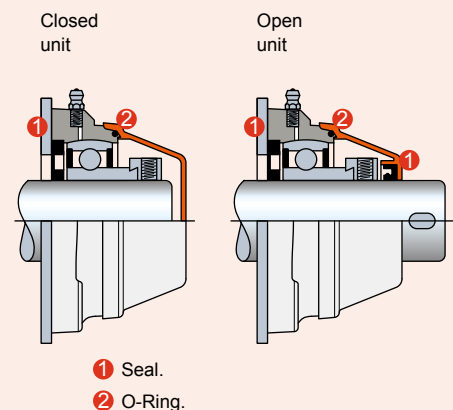

- ① Seal.
- ② O-Ring.

# UCFN/C - SUCFN/C - HCFN/C - SHCFN/C

dia. d mm	Series	Housing material		Dimensions in mm										Bore in frame <sup>1)</sup> Df		Bearing	Weight Kg	Spare parts Cover orange <b>Code</b>
		Polyamide PA FV Solid Flange (black) Cover (orange)	Polypropylene PP FV Solid Flange (white) Cover (orange)	e	a	s	g	i	z	t	Dg	max.	min.					
		<b>Code</b>	<b>Code</b>															
<b>Grub screws shaft locking • Closed unit</b>																		
30	UCFN 206 C	<b>632223</b>	<b>632463</b>	83	110	11	15	20	42	55	62	60	50	Type A	0,50	63154		
35*	SUCFN 207 C	<b>632233</b>	<b>632473</b>	83	110	11	15	19,5	43	59	72	70	55	Type A	0,61	682022		
40*	SUCFN 208 C	<b>632243</b>	<b>632483</b>	83	110	11	15	19	44	66	80	78	65	Type A	0,82	600882		
<b>Grub screws shaft locking • Open unit</b>																		
30	UCFN 206 C	<b>632253</b>	<b>632493</b>	83	110	11	15	20	42	55	62	60	50	Type A	0,50	69965		
35*	SUCFN 207 C	<b>632263</b>	<b>632503</b>	83	110	11	15	19,5	43	59	72	70	55	Type A	0,61	682032		
40*	SUCFN 208 C	<b>632273</b>	<b>632513</b>	83	110	11	15	19	44	66	80	78	65	Type A	0,82	600892		
<b>Eccentric collar shaft locking • Closed unit</b>																		
30	HCFN 206 C	<b>632283</b>	<b>632523</b>	83	110	11	15	20	46,7	55	62	60	50	Type D	0,57	63154		
35*	SHCFN 207 C	<b>632293</b>	<b>632533</b>	83	110	11	15	19,5	48,9	59	72	70	55	Type D	0,79	682022		
40*	SHCFN 208 C	<b>632303</b>	<b>632543</b>	83	110	11	15	19	51,7	66	80	78	65	Type D	1,01	600882		
<b>Eccentric collar shaft locking • Open unit</b>																		
30	HCFN 206 C	<b>632313</b>	<b>632553</b>	83	110	11	15	20	46,7	55	62	60	50	Type D	0,57	69965		
35*	SHCFN 207 C	<b>632323</b>	<b>632563</b>	83	110	11	15	19,5	48,9	59	72	70	55	Type D	0,79	682032		
40*	SHCFN 208 C	<b>632333</b>	<b>632573</b>	83	110	11	15	19	51,7	66	80	78	65	Type D	1,01	600892		

**Item code for order = B0000 + Code**

\* = Version with special fixing holes.

<sup>1)</sup> = Dimensions Df max / Df min must be respected to ensure positive retention of the seals and to allow air bleeding during lubrication.

Packaging: 6 pieces.

# Square flange bearing units

UCFN/CL - SUCFN/CL - HCFN/CL - SHCFN/CL



**LIFE LUBRICATED**



**Dry use recommended**



## Life lubricated

The ball-bearings are pre-lubricated with a special grease keeping the bearing for its whole life. No need for re-lubrication (see page B78 to calculate the grease life).

## Grub screws or eccentric collar shaft locking

## PA FV polyamide housing

High mechanical and heat resistance. Proof to dust, humidity, washouts, steam, average aggressive chemical agents.

## Solid flange bearings

Closed surface structure, ideal for sanitation.

## Material

### PA FV polyamide housing

- Housing in reinforced polyamide PA FV resin (black)
- Protection cover in polypropylene PP (orange)
- Seal and O-Ring in NBR rubber (black)
- Reinforcing bushings on mounting holes and washers in stainless steel AISI 304.

## Continuous operating temperature

in air: - 20 to + 60°C.

## Maximum allowed misalignment: 2°.

## Bearing



- Type A (grub screws shaft locking)
- Type D (eccentric collar shaft locking)
- Chrome alloy steel
- Superagriseal unit
- Prelubricated with lithium / calcium grease, no need for re-lubrication.

### • Series UCFN/CL • Type A Grub screws shaft locking

### • Series HCFN/CL • Type D Eccentric collar shaft locking

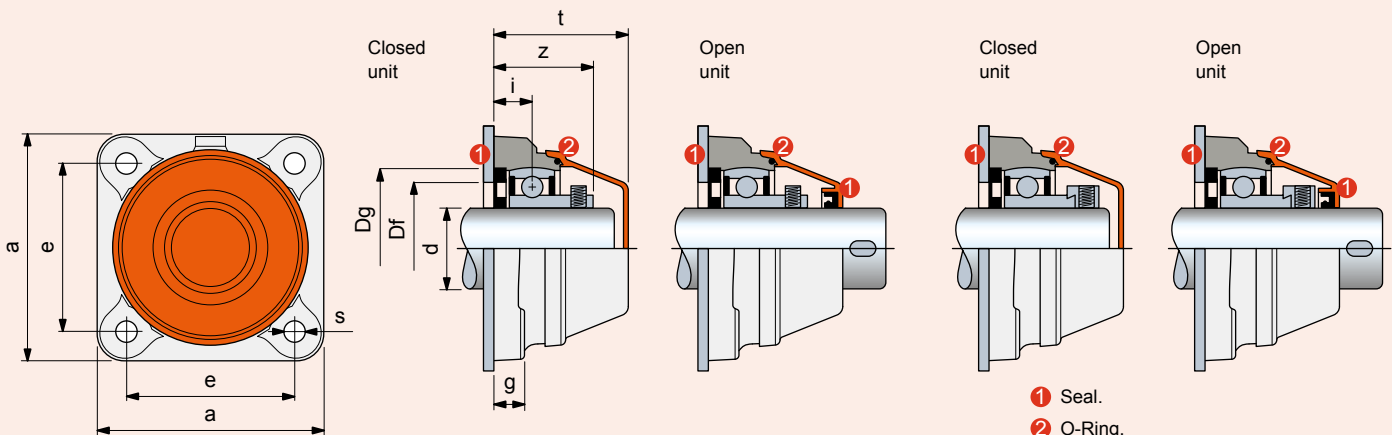

- 1 Seal.
- 2 O-Ring.

# UCFN/CL - SUCFN/CL - HCFN/CL - SHCFN/CL

dia. d mm	Series	Housing material		Dimensions in mm										Bore in frame Df		Bearing	Spare parts	
		Polyamide PA FV Solid Flange (black) Cover (orange)	Code	e	a	s	g	i	z	t	Dg	max.	min.	Weight Kg	Code			
<b>Grub screws shaft locking • Closed unit</b>																		
30	UCFN 206 CL	632223L	83	110	11	15	20	42	55	62	60	50	Type A	0,50	63154			
35*	SUCFN 207 CL	632233L	83	110	11	15	19,5	43	59	72	70	55	Type A	0,61	682022			
40*	SUCFN 208 CL	632243L	83	110	11	15	19	44	66	80	78	65	Type A	0,82	600882			
<b>Grub screws shaft locking • Open unit</b>																		
30	UCFN 206 CL	632253L	83	110	11	15	20	42	55	62	60	50	Type A	0,50	69965			
35*	SUCFN 207 CL	632263L	83	110	11	15	19,5	43	59	72	70	55	Type A	0,61	682032			
40*	SUCFN 208 CL	632273L	83	110	11	15	19	44	66	80	78	65	Type A	0,82	600892			
<b>Eccentric collar shaft locking • Closed unit</b>																		
30	HCFN 206 CL	632283L	83	110	11	15	20	46,7	55	62	60	50	Type D	0,57	63154			
35*	SHCFN 207 CL	632293L	83	110	11	15	19,5	48,9	59	72	70	55	Type D	0,79	682022			
40*	SHCFN 208 CL	632303L	83	110	11	15	19	51,7	66	80	78	65	Type D	1,01	600882			
<b>Eccentric collar shaft locking • Open unit</b>																		
30	HCFN 206 CL	632313L	83	110	11	15	20	46,7	55	62	60	50	Type D	0,57	69965			
35*	SHCFN 207 CL	632323L	83	110	11	15	19,5	48,9	59	72	70	55	Type D	0,79	682032			
40*	SHCFN 208 CL	632333L	83	110	11	15	19	51,7	66	80	78	65	Type D	1,01	600892			

**Item code for order = B0000 + Code**

\* = Version with special fixing holes.

Packaging: 6 pieces.



# Square flange bearing units

**UCFN - SUCFN - HCFN - SHCFN**



Accessories

**Material**

**PA FV polyamide housing**

- Housing in reinforced polyamide PA FV resin (black)
- Ball type nickel plated brass greasing nipple
- Reinforcing bushings on mounting holes and washers in stainless steel AISI 304.

**PP FV polypropylene housing**

- Housing in reinforced polypropylene PP FV resin (white)
- Bearing in stainless steel AISI 420
- Ball type stainless steel AISI 316 greasing nipple
- Reinforcing bushings on mounting holes and washers in stainless steel AISI 316.

**Continuous operating temperature**

in air: - 20 to + 60°C.

**Maximum allowed misalignment: 2°.**

**Bearing**

- Type B (grub screws shaft locking, chrome alloy steel, Superagriseal unit plus centrifuging ring)
- Type C (grub screws shaft locking, stainless steel AISI 420, Superagriseal unit plus rubberised centrifuging ring)
- Type A (grub screws shaft locking, chrome alloy steel, Superagriseal unit)
- Type D (eccentric collar shaft locking, chrome alloy steel, Superagriseal unit)
- Prelubricated with lithium / calcium grease
- Can be relubricated.

**Grub screws or eccentric collar shaft locking**

**Version with bearing Type B**

The double ring guarantees maximum protection against dust and non-corrosive substances.

**Version with stainless steel bearing Type C**

AISI 420 stainless steel bearing with 2 rubberised rings, provides excellent seal against humidity, steams, liquids, medium corrosive chemical agents. Maximum load ability is inferior.

**Version with bearing Type A**

The rubberised ring guarantees maximum protection against dusts.

**Material**

Polyamide PA FV guarantees maximum strength and high-temperature resistance. Polypropylene PP FV offers excellent resistance to chemical agents but inferior load ability.

**Protection covers (accessories)**

**Closed cover**

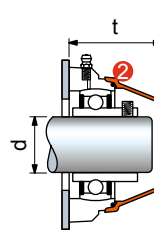

**Open cover**

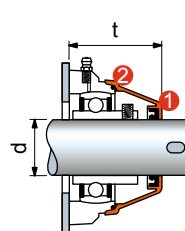

- 1 Seals.
- 2 Seals O-Ring.

dia. d mm	Accessories Cover orange	t mm
	Code	
<b>Closed cover supplied with seals</b>		
30	63154	55
35*	682022	59
40*	600882	66
<b>Open cover supplied with seals</b>		
30	69965	55
35*	682032	59
40*	600892	66

\* = Version with special fixing holes.

• Series UCFN • Type B  
Grub screws shaft locking

• Series UCFN • Type C  
Grub screws shaft locking

• Series UCFN • Type A  
Grub screws shaft locking

• Series HCFN • Type D  
Eccentric collar shaft locking

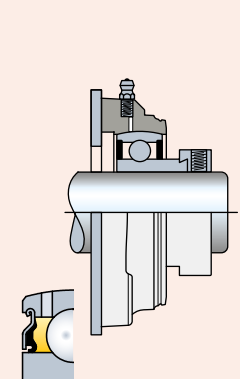
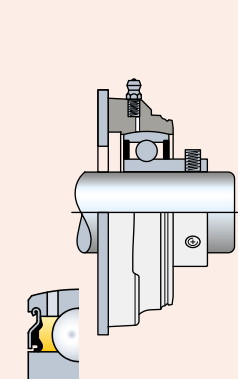
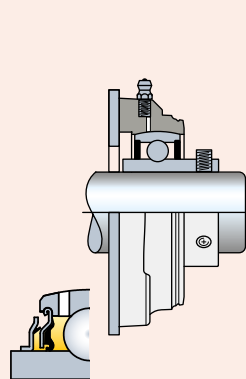
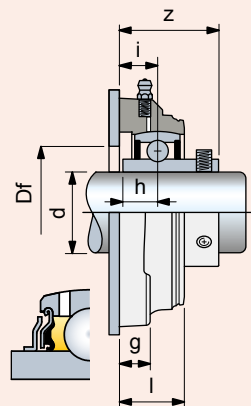
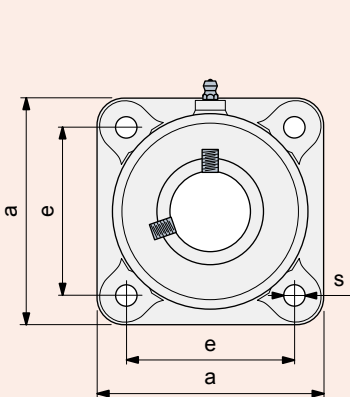

# UCFN - SUCFN - HCFN - SHCFN

dia. d mm	Series	Housing material		Dimensions in mm								Bore in frame Df mm	Bearing	Weight Kg
		Polyamide PA FV Solid Flange (black)	Polypropylene PP FV Solid Flange (white)	e	a	s	g	i	h	l	z			
<b>Grub screws shaft locking • Version with bearing Type B</b>														
30	UCFN 206	<b>634103</b>	-	83	110	11	15	20	15,9	31,5	42,2	34	Type B	0,51
35*	SUCFN 207	<b>634113</b>	-	83	110	11	15	19,5	17,5	31,5	44,9	39	Type B	0,59
40*	SUCFN 208	<b>634123</b>	-	83	110	11	15	19	19	31,5	49,2	44	Type B	0,82
<b>Grub screws shaft locking • Version with stainless steel bearing Type C</b>														
30	UCFN 206	<b>634133</b>	<b>634313</b>	83	110	11	15	20	15,9	31,5	42,2	34	Type C	0,51
35*	SUCFN 207	<b>634143</b>	<b>634323</b>	83	110	11	15	19,5	17,5	31,5	44,9	39	Type C	0,59
40*	SUCFN 208	<b>634153</b>	<b>634333</b>	83	110	11	15	19	19	31,5	49,2	44	Type C	0,82
<b>Grub screws shaft locking • Version with bearing Type A</b>														
30	UCFN 206	<b>634163</b>	<b>634343</b>	83	110	11	15	20	-	31,5	42	34	Type A	0,48
35*	SUCFN 207	<b>634173</b>	<b>634353</b>	83	110	11	15	19,5	-	31,5	43	39	Type A	0,56
40*	SUCFN 208	<b>634183</b>	<b>634363</b>	83	110	11	15	19	-	31,5	44	44	Type A	0,79
<b>Eccentric collar shaft locking • Version with bearing Type D</b>														
30	HCFN 206	<b>634193</b>	<b>634373</b>	83	110	11	15	20	-	31,5	46,7	34	Type D	0,55
35*	SHCFN 207	<b>634203</b>	<b>634383</b>	83	110	11	15	19,5	-	31,5	48,9	39	Type D	0,76
40*	SHCFN 208	<b>634213</b>	<b>634393</b>	83	110	11	15	19	-	31,5	51,7	44	Type D	0,98

**Item code for order = B0000 + Code**

\* = Version with special fixing holes.

Packaging: 6 pieces.

**Best Seller**

**Standard**

**On request**

# Square flange bearing units

UCF/C - SUCF/C - HCF/C - SHCF/C



## Waterproof housing

### Grub screws or eccentric collar shaft locking

#### PA FV polyamide housing

High mechanical and heat resistance. Proof to dust, humidity, washouts, steam, average aggressive chemical agents.

#### PP FV polypropylene housing

Proof to highly aggressive chemical agents. Inferior loading ability.

#### Solid flange bearings

They differ from standard flange versions for their closed surface structure, ideal for sanitation.

## Material

### PA FV polyamide housing

- Housing in reinforced polyamide PA FV resin (black)
- Protection cover in polypropylene PP (orange)
- Seal and O-Ring in NBR rubber (black)
- Ball type nickel plated brass greasing nipple
- Reinforcing bushings on mounting holes and washers in stainless steel AISI 304

### PP FV polypropylene housing

- Housing in reinforced polypropylene PP FV resin (white)
- Protection cover in polypropylene PP (orange)
- Seal and O-Ring in NBR rubber (black).  
On request supplied in Viton rubber (brown).  
Viton material offers high resistance to chemical agents
- Ball type stainless steel AISI 316 greasing nipple
- Reinforcing bushings on mounting holes and washers in stainless steel AISI 316.

## Continuous operating temperature

in air: - 20 to + 60°C.

## Maximum allowed misalignment: 2°.

## Bearing



- Type A (grub screws shaft locking)
- Type D (eccentric collar shaft locking)
- Chrome alloy steel
- Superagriseal unit
- Prelubricated with lithium / calcium grease
- Can be relubricated.

### • Series UCF/C • Type A Grub screws shaft locking

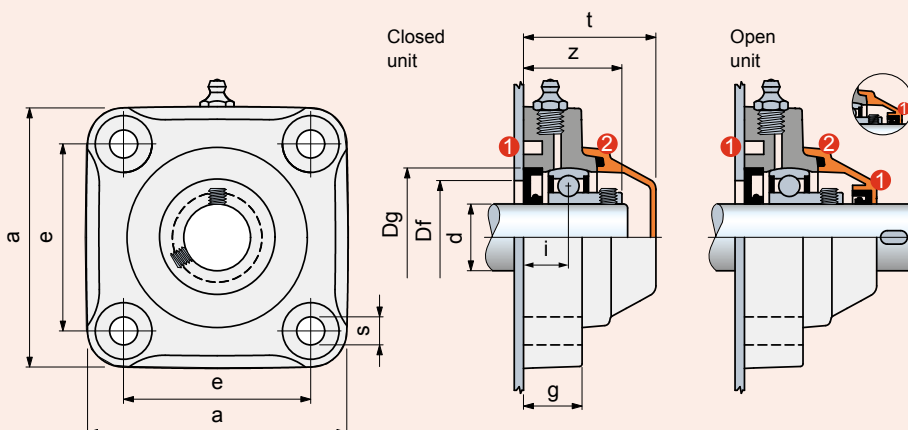

### • Series HCF/C • Type D Eccentric collar shaft locking

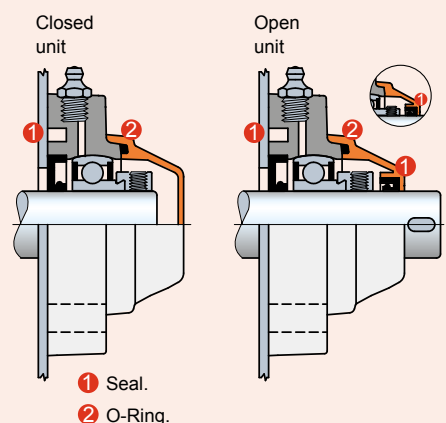

# UCF/C - SUCF/C - HCF/C - SHCF/C

dia. d mm	Series	Housing material		Dimensions in mm										Bore in frame <sup>2)</sup> Df		Bearing	Weight Kg	Spare parts Cover orange <b>Code</b>
		Polyamide PA FV Standard Flange (black) Cover (orange)	Polypropylene PP FV Solid Flange (white) Cover (orange)	e	a	s	g	i	z	t	Dg	max.	min.					
		<b>Code</b>																
<b>Grub screws shaft locking • Closed unit</b>																		
25	UCF 205 C	64573	680932	70	98	11	22,5	16,8	36,3	49,5	52	50	45	Type A	0,40	681952		
25*	SUCF 205 C	603043	-	83	110	11	26	19,3	38,8	54	52	50	45	Type A	0,50	681952		
30	UCF 206 C	63112	680942	83	110	11	26	20	42	56	62	60	50	Type A	0,56	63154		
35	UCF 207 C	64018	680952	92	120	11	26	19,5	43	59	72	70	55	Type A	0,72	682022		
35*	SUCF 207 C	680522 <sup>1)</sup>	680962	83	110	11	26	19,5	43	61	72	70	55	Type A	0,67	63539		
40	UCF 208 C	68916	680972	102	131	11	30	22	47	65,5	80	78	65	Type A	0,95	63539		
40*	SUCF 208 C	61819	680982	83	110	11	26	19	44	66	80	78	65	Type A	0,88	600882		
45*	SUCF 209 C	686592 <sup>1)</sup>	686752	102	131	11	30	23	54	73	85	83	75	Type A	1,10	686972		
50*	SUCF 210 C	686602 <sup>1)</sup>	686762	102	131	11	30	23	55,6	73	90	88	80	Type A	1,20	686972		
<b>Grub screws shaft locking • Open unit</b>																		
25	UCF 205 C	64623	680992	70	98	11	22,5	16,8	36,3	49,5	52	50	45	Type A	0,40	681972		
25*	SUCF 205 C	603053	-	83	110	11	26	19,3	38,8	54	52	50	45	Type A	0,50	681972		
30	UCF 206 C	63172	681002	83	110	11	26	20	42	56	62	60	50	Type A	0,56	69965		
35	UCF 207 C	64028	681012	92	120	11	26	19,5	43	59	72	70	55	Type A	0,72	682032		
35*	SUCF 207 C	680582 <sup>1)</sup>	681022	83	110	11	26	19,5	43	61	72	70	55	Type A	0,67	615692		
40	UCF 208 C	68926	681032	102	131	11	30	22	47	65,5	80	78	65	Type A	0,95	63549		
40*	SUCF 208 C	61829	681042	83	110	11	26	19	44	66	80	78	65	Type A	0,88	600892		
45*	SUCF 209 C	686612 <sup>1)</sup>	686772	102	131	11	30	23	54	73	85	83	75	Type A	1,10	686992		
50*	SUCF 210 C	686622 <sup>1)</sup>	686782	102	131	11	30	23	55,6	73	90	88	80	Type A	1,20	687002		
<b>Eccentric collar shaft locking • Closed unit</b>																		
25	HCF 205 C	680452	681052	70	98	11	22,5	16,8	40,2	49,5	52	50	45	Type D	0,44	681952		
25*	SHCF 205 C	603063	-	83	110	11	26	19,3	42,7	54	52	50	45	Type D	0,57	681952		
30	HCF 206 C	621501	681062	83	110	11	26	20	46,7	56	62	60	50	Type D	0,63	63154		
35	HCF 207 C	680462	681072	92	120	11	26	19,5	48,9	59	72	70	55	Type D	0,90	682022		
35*	SHCF 207 C	680642 <sup>1)</sup>	681082	83	110	11	26	19,5	48,9	61	72	70	55	Type D	0,85	63539		
40*	SHCF 208 C	62439	681092	83	110	11	26	19	51,7	66	80	78	65	Type D	1,07	600882		
45*	SHCF 209 C	686632 <sup>1)</sup>	686792	102	131	11	30	23	55,7	73	85	83	75	Type D	1,29	686972		
50*	SHCF 210 C	686642	686802	102	131	11	30	23	55,7	73	90	88	80	Type D	1,39	686972		
<b>Eccentric collar shaft locking • Open unit</b>																		
25	HCF 205 C	680472	681102	70	98	11	22,5	16,8	40,2	49,5	52	50	45	Type D	0,44	681972		
25*	SHCF 205 C	603073	-	83	110	11	26	19,3	42,7	54	52	50	45	Type D	0,57	681972		
30	HCF 206 C	621481	681112	83	110	11	26	20	46,7	56	62	60	50	Type D	0,63	69965		
35	HCF 207 C	680482	681122	92	120	11	26	19,5	48,9	59	72	70	55	Type D	0,90	682032		
35*	SHCF 207 C	680692 <sup>1)</sup>	681132	83	110	11	26	19,5	48,9	61	72	70	55	Type D	0,85	615692		
40*	SHCF 208 C	62449	681142	83	110	11	26	19	51,7	66	80	78	65	Type D	1,07	600892		
45*	SHCF 209 C	686652 <sup>1)</sup>	686812	102	131	11	30	23	55,7	73	85	83	75	Type D	1,29	686992		
50*	SHCF 210 C	686662 <sup>1)</sup>	686822	102	131	11	30	23	55,7	73	90	88	80	Type D	1,39	687002		

## Item code for order = B0000 + Code

\* = Version with special fixing holes.

<sup>1)</sup> = Solid flange.

<sup>2)</sup> = Dimensions Df max / Df min must be respected to ensure positive retention of the seals and to allow air bleeding during lubrication.

Packaging: 6 pieces.

**Best Seller**

**Standard**

**On request**

# Square flange bearing units

UCF/CL - SUCF/CL - HCF/CL - SHCF/CL

**LIFE LUBRICATED**



**Dry use recommended**



## Life lubricated

The ball-bearings are pre-lubricated with a special grease keeping the bearing for its whole life. No need for re-lubrication (see page B78 to calculate the grease life)

## Grub screws or eccentric collar shaft locking

## PA FV polyamide housing

High mechanical and heat resistance. Proof to dust, humidity, washouts, steam, average aggressive chemical agents.

## Solid flange bearings

They differ from standard flange versions for their closed surface structure, ideal for sanitation.

## Material

### PA FV polyamide housing

- Housing in reinforced polyamide PA FV resin (black)
- Protection cover in polypropylene PP (orange)
- Seal and O-Ring in NBR rubber (black)
- Reinforcing bushings on mounting holes and washers in stainless steel AISI 304.

## Continuous operating temperature

in air: - 20 to + 60°C.

## Maximum allowed misalignment: 2°.

## Bearing



- Type A (grub screws shaft locking)
- Type D (eccentric collar shaft locking)
- Chrome alloy steel
- Superagriseal unit
- Pre-lubricated with lithium / calcium grease, no need for re-lubrication.

### • Series UCF/CL • Type A Grub screws shaft locking

### • Series HCF/CL • Type D Eccentric collar shaft locking

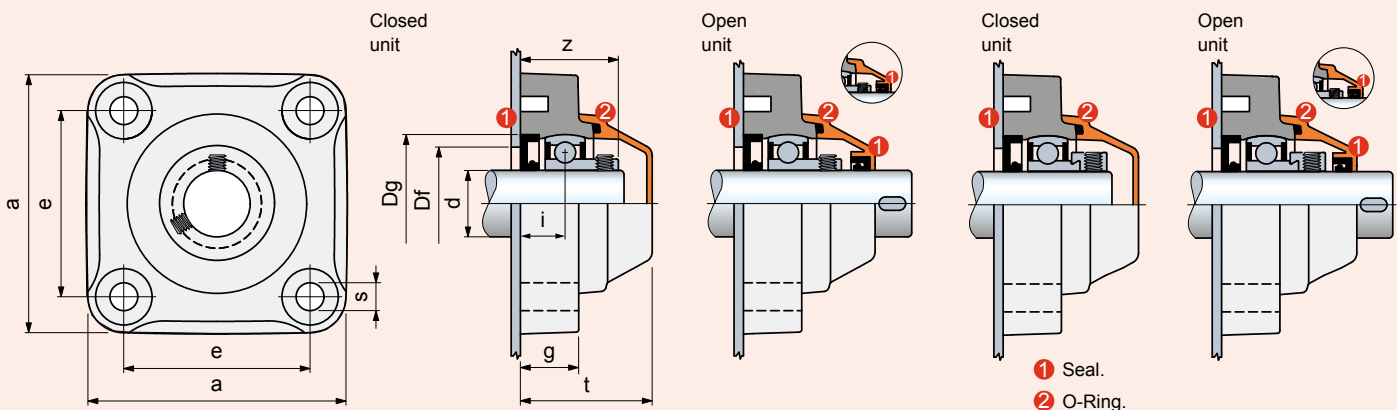

# UCF/CL - SUCF/CL - HCF/CL - SHCF/CL

dia. d mm	Series	Housing material		Dimensions in mm										Bore in frame Df		Bearing	Spare parts Cover orange	
		Polyamide PA FV Standard Flange (black) Cover (orange)	Code	e	a	s	g	i	z	t	Dg	max.	min.	Weight Kg	Code			
<b>Grub screws shaft locking • Closed unit</b>																		
25	UCF 205 CL	64573L	70	98	11	22,5	16,8	36,3	49,5	52	50	45	Type A	0,40	681952			
25*	SUCF 205 CL	603043L	83	110	11	26	19,3	38,8	54	52	50	45	Type A	0,50	681952			
30	UCF 206 CL	63112L	83	110	11	26	20	42	56	62	60	50	Type A	0,56	63154			
35	UCF 207 CL	64018L	92	120	11	26	19,5	43	59	72	70	55	Type A	0,72	682022			
40	UCF 208 CL	68916L	102	131	11	30	22	47	65,5	80	78	65	Type A	0,95	63539			
40*	SUCF 208 CL	61819L	83	110	11	26	19	44	66	80	78	65	Type A	0,88	600882			
<b>Grub screws shaft locking • Open unit</b>																		
25	UCF 205 CL	64623L	70	98	11	22,5	16,8	36,3	49,5	52	50	45	Type A	0,40	681972			
25*	SUCF 205 CL	603053L	83	110	11	26	19,3	38,8	54	52	50	45	Type A	0,50	681972			
30	UCF 206 CL	63172L	83	110	11	26	20	42	56	62	60	50	Type A	0,56	69965			
35	UCF 207 CL	64028L	92	120	11	26	19,5	43	59	72	70	55	Type A	0,72	682032			
40	UCF 208 CL	68926L	102	131	11	30	22	47	65,5	80	78	65	Type A	0,95	63549			
40*	SUCF 208 CL	61829L	83	110	11	26	19	44	66	80	78	65	Type A	0,88	600892			
<b>Eccentric collar shaft locking • Closed unit</b>																		
25	HCF 205 CL	680452L	70	98	11	22,5	16,8	40,2	49,5	52	50	45	Type D	0,44	681952			
25*	SHCF 205 CL	603063L	83	110	11	26	19,3	42,7	54	52	50	45	Type D	0,57	681952			
30	HCF 206 CL	621501L	83	110	11	26	20	46,7	56	62	60	50	Type D	0,63	63154			
35	HCF 207 CL	680462L	92	120	11	26	19,5	48,9	59	72	70	55	Type D	0,90	682022			
40*	SHCF 208 CL	62439L	83	110	11	26	19	51,7	66	80	78	65	Type D	1,07	600882			
<b>Eccentric collar shaft locking • Open unit</b>																		
25	HCF 205 CL	680472L	70	98	11	22,5	16,8	40,2	49,5	52	50	45	Type D	0,44	681972			
25*	SHCF 205 CL	603073L	83	110	11	26	19,3	42,7	54	52	50	45	Type D	0,57	681972			
30	HCF 206 CL	621481L	83	110	11	26	20	46,7	56	62	60	50	Type D	0,63	69965			
35	HCF 207 CL	680482L	92	120	11	26	19,5	48,9	59	72	70	55	Type D	0,90	682032			
40*	SHCF 208 CL	62449L	83	110	11	26	19	51,7	66	80	78	65	Type D	1,07	600892			

**Item code for order = B0000 + Code**

\* = Version with special fixing holes.

Packaging: 6 pieces.

# Square flange bearing units

## UCF - SUCF - HCF - SHCF



Accessories

### Material

#### PA FV polyamide housing

- Housing in reinforced polyamide PA FV resin (black)
- Ball type nickel plated brass greasing nipple
- Reinforcing bushings on mounting holes and washers in stainless steel AISI 304.

#### PP FV polypropylene housing

- Housing in reinforced polypropylene PP FV resin (white)
- Bearing in stainless steel AISI 420
- Ball type stainless steel AISI 316 greasing nipple
- Reinforcing bushings on mounting holes and washers in stainless steel AISI 316.

### Continuous operating temperature

in air: - 20 to + 60°C.

### Maximum allowed misalignment: 2°.

### Bearing

- Type B (grub screws shaft locking, chrome alloy steel, Superagriseal unit plus centrifuging ring)
- Type C (grub screws shaft locking, stainless steel AISI 420, Superagriseal unit plus rubberised centrifuging ring)
- Type A (grub screws shaft locking, chrome alloy steel, Superagriseal unit)
- Type D (eccentric collar shaft locking, chrome alloy steel, Superagriseal unit)
- Prelubricated with lithium / calcium grease
- Can be relubricated.

### Grub screws or eccentric collar shaft locking

#### Version with bearing Type B

The double ring guarantees maximum protection against dust and non-corrosive substances.

#### Version with stainless steel bearing Type C

AISI 420 stainless steel bearing with 2 rubberised rings, provides excellent seal against humidity, steams, liquids, medium corrosive chemical agents. Maximum load ability is inferior.

#### Version with bearing Type A

The rubberised ring guarantees maximum protection against dusts.

### Material

Polyamide PA FV guarantees maximum strength and high-temperature resistance. Polypropylene PP FV offers excellent resistance to chemical agents but inferior load ability.

### Protection covers (accessories)

#### Closed cover

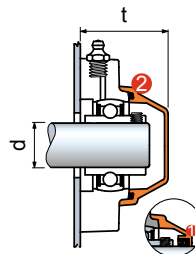

Dia 45/50 supplied without o-ring

#### Open cover

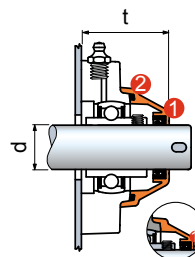

Dia 45/50 supplied without o-ring

① Seals.

② Seals O-Ring.

dia. d mm	Accessories Cover orange	t mm
	Code	
<b>Closed cover supplied with seals</b>		
25	681952	49,5
25*	681952	54
30	63154	56
35	682022	59
35* Standard	63154	54,6
35* Solid	63539	61
40	63539	65,5
40*	600882	66
45*	686972	73
50*	686972	73
<b>Open cover supplied with seals</b>		
25	681972	49,5
25*	681972	54
30	69965	56
35	682032	59
35* Standard	-	-
35* Solid	615692	61
40	63549	65,5
40*	600892	66
45*	686992	73
50*	687002	73

\* = Version with special fixing holes.

• Series UCF • Type B  
Grub screws shaft  
locking

• Series UCF • Type C  
Grub screws shaft  
locking

• Series UCF • Type A  
Grub screws shaft  
locking

• Series HCF • Type D  
Eccentric collar shaft  
locking

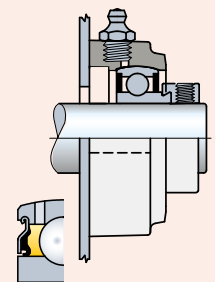
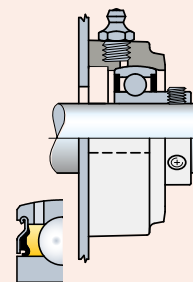
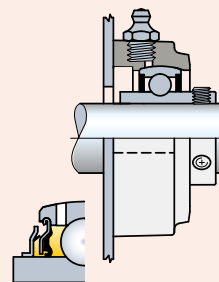
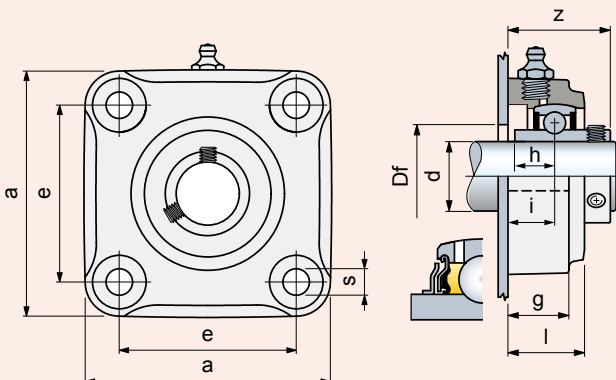

dia. d mm	Series	Housing material		Dimensions in mm									Bore in frame Df mm	Bearing	Weight Kg
		Polyamide PA FV Standard Flange (black)	Polypropylene PP FV Solid Flange (white)	e	a	s	g	i	h	l	z				
		Code													
<b>Grub screws shaft locking • Version with bearing Type B</b>															
25	UCF 205	64533	-	70	98	11	22,5	16,8	14,3	27,5	36,5	29	Type B	0,44	
25*	SUCF 205	603163	-	83	110	11	26	19,3	14,3	31,5	39	29	Type B	0,51	
30	UCF 206	60722	-	83	110	11	26	20	15,9	32,5	42,2	34	Type B	0,57	
35	UCF 207	64058	-	92	120	11	26	19,5	17,5	32	44,9	39	Type B	0,72	
35*	SUCF 207	68465	-	83	110	11	26	15,5	17,5	31,5	40,9	50	Type B	0,65	
40	UCF 208	68956	-	102	131	11	30	22	19	36	52,2	44	Type B	0,95	
40*	SUCF 208	61719	-	83	110	11	26	19	19	36	49,2	55	Type B	0,88	
45*	SUCF 209	689232	-	102	131	11	30	23	19	38	53,2	49	Type B	0,95	
50*	SUCF 210	689242	-	102	131	11	30	23	19	38	55,6	54	Type B	0,88	
<b>Grub screws shaft locking • Version with stainless steel bearing Type C</b>															
25	UCF 205	646592	681642	70	98	11	22,5	16,8	14,3	27,5	36,6	29	Type C	0,44	
30	UCF 206	646602	681652	83	110	11	26	20	15,9	32,5	42,2	34	Type C	0,57	
35	UCF 207	646612	681662	92	120	11	26	19,5	17,5	32	44,9	39	Type C	0,72	
35*	SUCF 207	646622	681672	83	110	11	26	15,5*	17,5	31,5	40,9	50	Type C	0,65	
40	UCF 208	646632	681682	102	131	11	30	22	19	36	52,2	44	Type C	0,95	
40*	SUCF 208	646642	681692	83	110	11	26	19	19	36	49,2	55	Type C	0,88	
<b>Grub screws shaft locking • Version with bearing Type A</b>															
25	UCF 205	656752	681282	70	98	11	22,5	16,8	-	27,5	36,3	29	Type A	0,39	
25*	SUCF 205	603143	-	83	110	11	26	19,3	-	31,5	38,8	29	Type A	0,48	
30	UCF 206	666442	681292	83	110	11	26	20	-	32,5	42	34	Type A	0,54	
35	UCF 207	666452	681302	92	120	11	26	19,5	-	32	43	39	Type A	0,69	
35*	SUCF 207	682062	681312	83	110	11	26	15,5*	-	31,5	39	39	Type A	0,62	
40	UCF 208	666462	681322	102	131	11	30	22	-	36	47	44	Type A	0,92	
40*	SUCF 208	681552	681332	83	110	11	26	19	-	36	44	44	Type A	0,85	
45*	SUCF 209	686852	686892	102	131	11	30	23	-	38	54	49	Type A	0,87	
50*	SUCF 210	686862	686902	102	131	11	30	23	-	38	55,6	54	Type A	1,04	
<b>Eccentric collar shaft locking • Version with bearing Type D</b>															
25	HCF 205	681562	681502	70	98	11	22,5	16,8	-	27,5	40,2	29	Type D	0,43	
25*	SHCF 205	603153	-	83	110	11	26	19,3	-	31,5	42,7	29	Type D	0,55	
30	HCF 206	62329	681512	83	110	11	26	20	-	32,5	46,7	34	Type D	0,61	
35	HCF 207	681572	681522	92	120	11	26	19,5	-	32	48,9	39	Type D	0,87	
35*	SHCF 207	681392 <sup>1)</sup>	681532	83	110	11	26	19,5	-	31,5	48,9	39	Type D	0,82	
40*	SHCF 208	62349	681542	83	110	11	26	19	-	36	51,7	44	Type D	1,04	
45*	SHCF 209	686912	686952	102	131	11	30	23	-	38	55,7	49	Type D	0,87	
50*	SHCF 210	686922	686962	102	131	11	30	23	-	38	55,7	54	Type D	1,04	

Item code for order = B0000 + Code

\* = Version with special fixing holes.

<sup>1)</sup> = Solid flange.

• = Solid flange 19,5.

Packaging: 6 pieces.



# Square flange bearing units

UCFS/C - SUCFS/C - HCFS/C - SHCFS/C

Austenitic stainless steel surface

Waterproof housing

Grub screws or eccentric collar shaft locking

Solid flange

Closed surface structure.



## Material

- Housing in reinforced polyamide PA FV resin (black)
- Austenitic stainless steel surface
- Protection cover in polypropylene PP (orange)
- Seal and O-Ring in NBR rubber (black)
- Ball type nickel plated brass greasing nipple.

## Continuous operating temperature

in air: - 20 to + 60°C.

## Maximum allowed misalignment: 2°.

## Bearing



- Type A (grub screws shaft locking)
- Type D (eccentric collar shaft locking)
- Chrome alloy steel
- Superagriseal unit
- Prelubricated with lithium / calcium grease
- Can be relubricated.

### • Series UCFS/C • Type A Grub screws shaft locking

### • Series HCFS/C • Type D Eccentric collar shaft locking

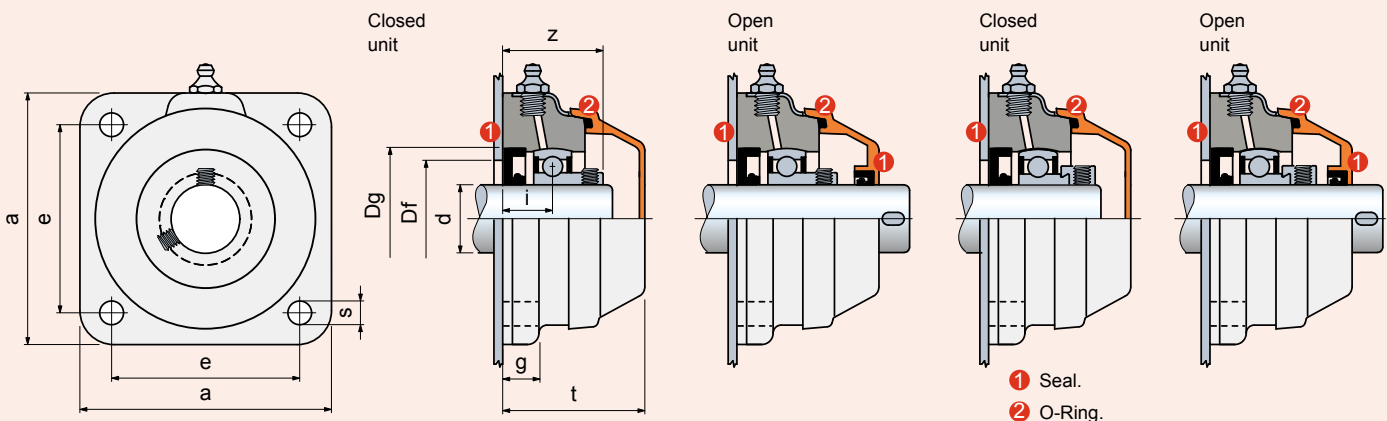

# UCFS/C - SUCFS/C - HCFS/C - SHCFS/C

dia. d mm	Series	Housing material	Dimensions in mm										Bore in frame <sup>1)</sup> Df		Bearing	Weight Kg	Spare parts Cover orange	
		Polyamide PA FV with austenitic stainless steel surface Solid Flange Cover (orange)	e	a	s	g	i	z	t	Dg	max.	min.	Code					
<b>Grub screws shaft locking • Closed unit</b>																		
30	UCFS 206 C	647613	83	111	10,5	15,9	22	44	65,8	62	60	50	Type A	0,73	63539			
35*	SUCFS 207 C	647623	83	111	10,5	15,9	22	45,5	65,8	72	70	55	Type A	0,84	63539			
40*	SUCFS 208 C	647633	83	111	10,5	15,9	22	47	65,8	80	78	65	Type A	0,94	63539			
<b>Grub screws shaft locking • Open unit</b>																		
30	UCFS 206 C	647643	83	111	10,5	15,9	22	44	65,8	62	60	50	Type A	0,73	615682			
35*	SUCFS 207 C	647653	83	111	10,5	15,9	22	45,5	65,8	72	70	55	Type A	0,84	615692			
40*	SUCFS 208 C	647663	83	111	10,5	15,9	22	47	65,8	80	78	65	Type A	0,94	63549			
<b>Eccentric collar shaft locking • Closed unit</b>																		
30	HCFS 206 C	647673	83	111	10,5	15,9	22	48,7	65,8	62	60	50	Type D	0,80	63539			
35*	SHCFS 207 C	647683	83	111	10,5	15,9	22	51,4	65,8	72	70	55	Type D	0,90	63539			
40*	SHCFS 208 C	647693	83	111	10,5	15,9	19	51,7	65,8	80	78	65	Type D	1,00	63539			
<b>Eccentric collar shaft locking • Open unit</b>																		
30	HCFS 206 C	647703	83	111	10,5	15,9	22	48,7	65,8	62	60	50	Type D	0,80	615682			
35*	SHCFS 207 C	647713	83	111	10,5	15,9	22	51,4	65,8	72	70	55	Type D	0,90	615692			
40*	SHCFS 208 C	647723	83	111	10,5	15,9	19	51,7	65,8	80	78	65	Type D	1,00	63549			

**Item code for order = B0000 + Code**

\* = Version with special fixing holes.

<sup>1)</sup> = Dimensions Df max / Df min must be respected to ensure positive retention of the seals and to allow air bleeding during lubrication.

Packaging: 6 pieces.

# Square flange bearing units

**F - SF**



**Waterproof housing**

**Shaft shoulders locking**

High axial load capacity.

**PA FV polyamide housing**

High mechanical and heat resistance. Proof to dust, humidity, washouts, steam, average aggressive chemical agents.

**PP FV polypropylene housing**

Proof to highly aggressive chemical agents. Inferior loading ability.

## Material

### PA FV polyamide housing

- Housing in reinforced polyamide PA FV resin (black)
- Seal and O-Ring in NBR rubber (black)
- Ball type nickel plated brass greasing nipple
- Reinforcing bushings on mounting holes and washers in stainless steel AISI 304.

### PP FV polypropylene housing

- Housing in reinforced polypropylene PP FV resin (black)
- Seal and O-Ring in NBR rubber (black).
- On request supplied in Viton rubber (brown).
- Viton material offers high resistance to chemical agents.
- Ball type stainless steel AISI 316 greasing nipple
- Reinforcing bushings on mounting holes and washers in stainless steel AISI 316.

## Continuous operating temperature

in air: - 20 to + 60°C.

## Maximum allowed misalignment: 2°.

## Bearing

- Type 1200 self aligning ball bearing
- Chrome alloy steel
- Supplied without grease
- To be prelubricated with lithium / calcium grease during first installation.

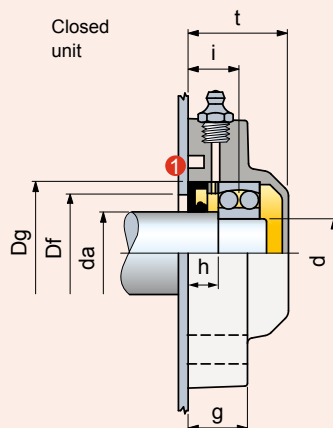
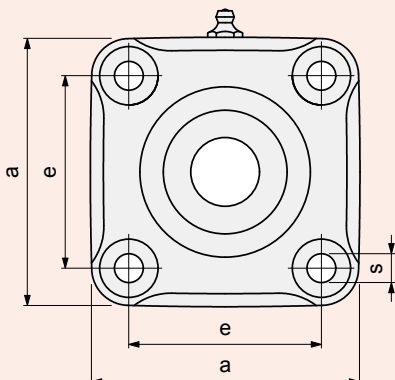

Open unit

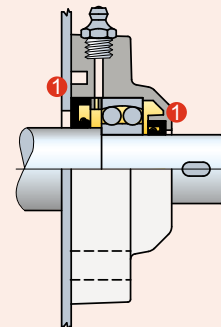

1 Seal.

Shaft dia. da mm	Bearing dia. d mm	Series	Housing material		Dimensions in mm										Bore in frame <sup>1)</sup> Df		Bearing	Weight Kg
			Polyamide PA FV Standard Flange (black)	Polypropylene PP FV Standard Flange (black)	e	a	s	g	i	h	t	Dg	max.	min.				
			<b>Code</b>	<b>Code</b>														
<b>Closed unit</b>																		
30	25	F 1205	<b>64433</b>	<b>681702</b>	70	98	11	22,5	18,5	11	36,5	52	50	47	Type 1200	0,36		
35	30	F 1206	<b>65811</b>	<b>681712</b>	83	110	11	26	19	11	40	62	60	52	Type 1200	0,53		
40	35	F 1207	<b>63978</b>	<b>681722</b>	92	120	11	26	19,5	11	39,5	72	70	60	Type 1200	0,62		
40*	35*	SF 1207	<b>699782</b>	<b>699802</b>	83	110	11	26	19	10	39	72	70	60	Type 1200	0,60		
45	40	F 1208	<b>68876</b>	<b>681732</b>	102	131	11	30	24,5	15,5	45	80	78	65	Type 1200	0,85		
45*	40*	SF 1208	<b>69988</b>	<b>681742</b>	83	110	11	26	19	10	39	80	78	65	Type 1200	0,78		
<b>Open unit</b>																		
30	25	F 1205	<b>64483</b>	<b>681752</b>	70	98	11	22,5	18,5	11	36,5	52	50	47	Type 1200	0,36		
35	30	F 1206	<b>65901</b>	<b>681762</b>	83	110	11	26	19	11	40	62	60	52	Type 1200	0,53		
40	35	F 1207	<b>63988</b>	<b>681772</b>	92	120	11	26	19,5	11	39,5	72	70	60	Type 1200	0,62		
40*	35*	SF 1207	<b>699792</b>	<b>699812</b>	83	110	11	26	19	10	39	72	70	60	Type 1200	0,60		
45	40	F 1208	<b>68886</b>	<b>681782</b>	102	131	11	30	24,5	15,5	45	80	78	65	Type 1200	0,85		
45*	40*	SF 1208	<b>69998</b>	<b>681792</b>	83	110	11	26	19	10	39	80	78	65	Type 1200	0,78		

**Item code for order = B0000 + Code**

\* = Version with special fixing holes.

<sup>1)</sup> = Dimensions Df max / Df min must be respected to ensure positive retention of the seals and to allow air bleeding during lubrication.

Packaging: 6 pieces.