

Part. **S0756**

■ Pearl roller side guide

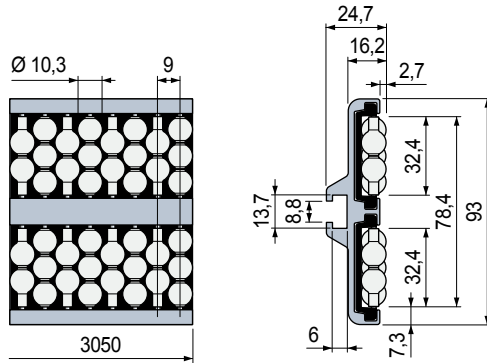

Pearl material	Code	Weight kg
Polyethylene PE (Aubergine)	645143	1,95
Polyethylene PE (white)	645153	

- Material: metal profile in anodized aluminium, rollers module in acetal POM (black), roller pins in stainless steel.
- Standard packaging: strands 3,05 metres.
- Packaging: 2 strands.

The roller side guides can be supplied with separated components.

Metal profile

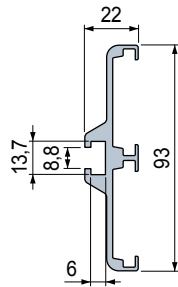

Pearls module

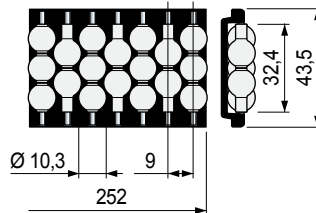

Length mm	Code	Pearl material	Code
3050	607953	Polyethylene PE (Aubergine)	644653
6100	607963	Polyethylene PE (white)	644633

- Material: anodized aluminium.
- Weight: 1,36 Kg/m.
- Packaging: 1 strand.

• Characteristics Part. S0756

- Self supporting structure.
- Anodized aluminium profile.
- Quick and easy installation by standard bolts.
- Can be used straight running and sideflexing.

• Assembly Part. S0756

M8 hex head bolt

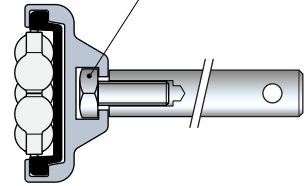

• Accessories

Part. S0369 - Connecting bar

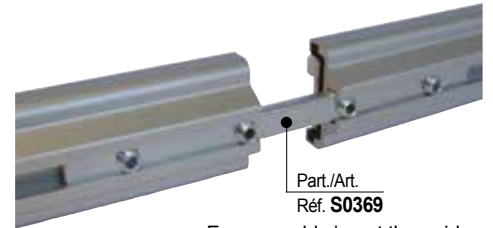

For assembly insert the guides and tighten the set screw.

• Min. curvature radius Part. S0756

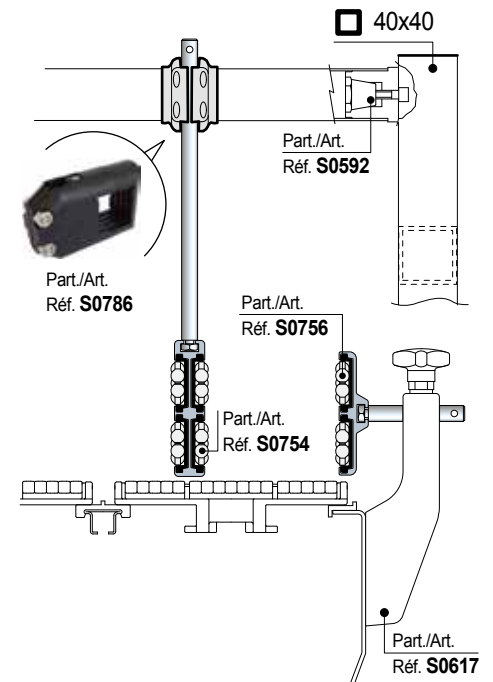
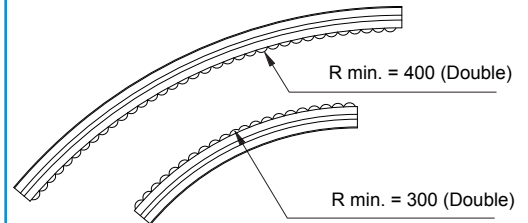

● Best Seller

● Standard

● On request: minimum quantity may apply. Consult our Customer Service for availability.

Item code for order = Part. + Code