

## Part. S0837

■ Technical information

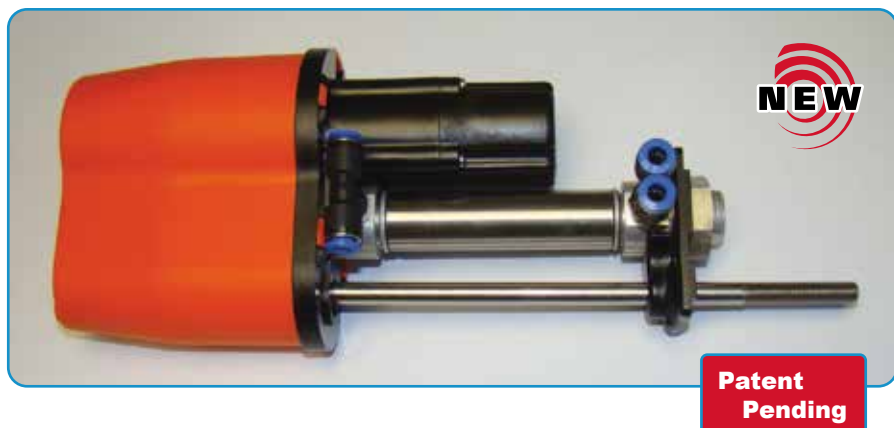

Code	Weight kg
640783	0,68

- Operating unit SGA™, on the positioning roller and fastening support in black acetalic POM.
- Safety cover in orange Polypropylene PP.
- Stop plate, rod clamp and M22 nut in stainless steel.
- Quick coupling in plastic.
- Mini-cylinder ISO 6432.
- Packaging: 4 pieces.

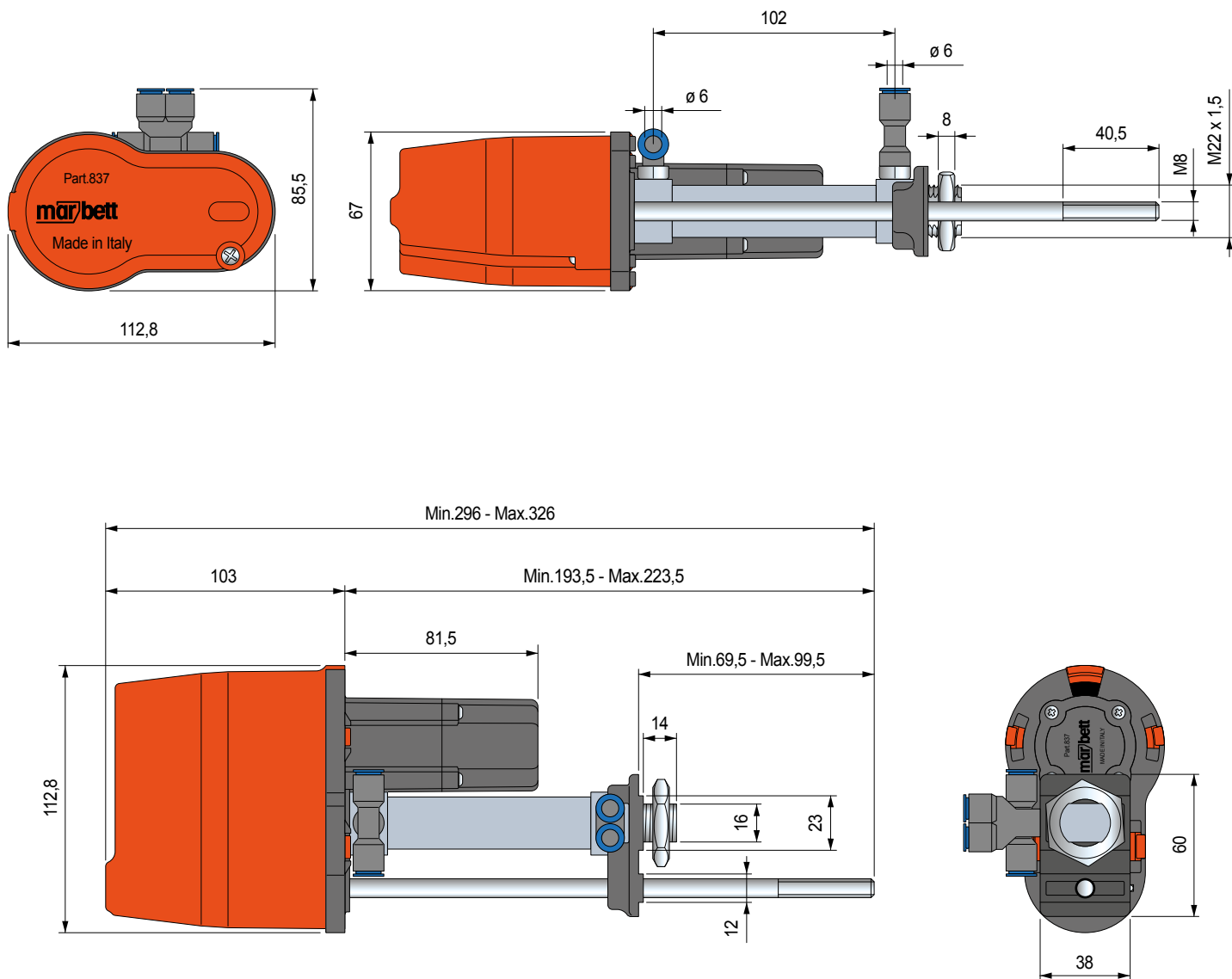

■ Component's description

Part. **S0837**

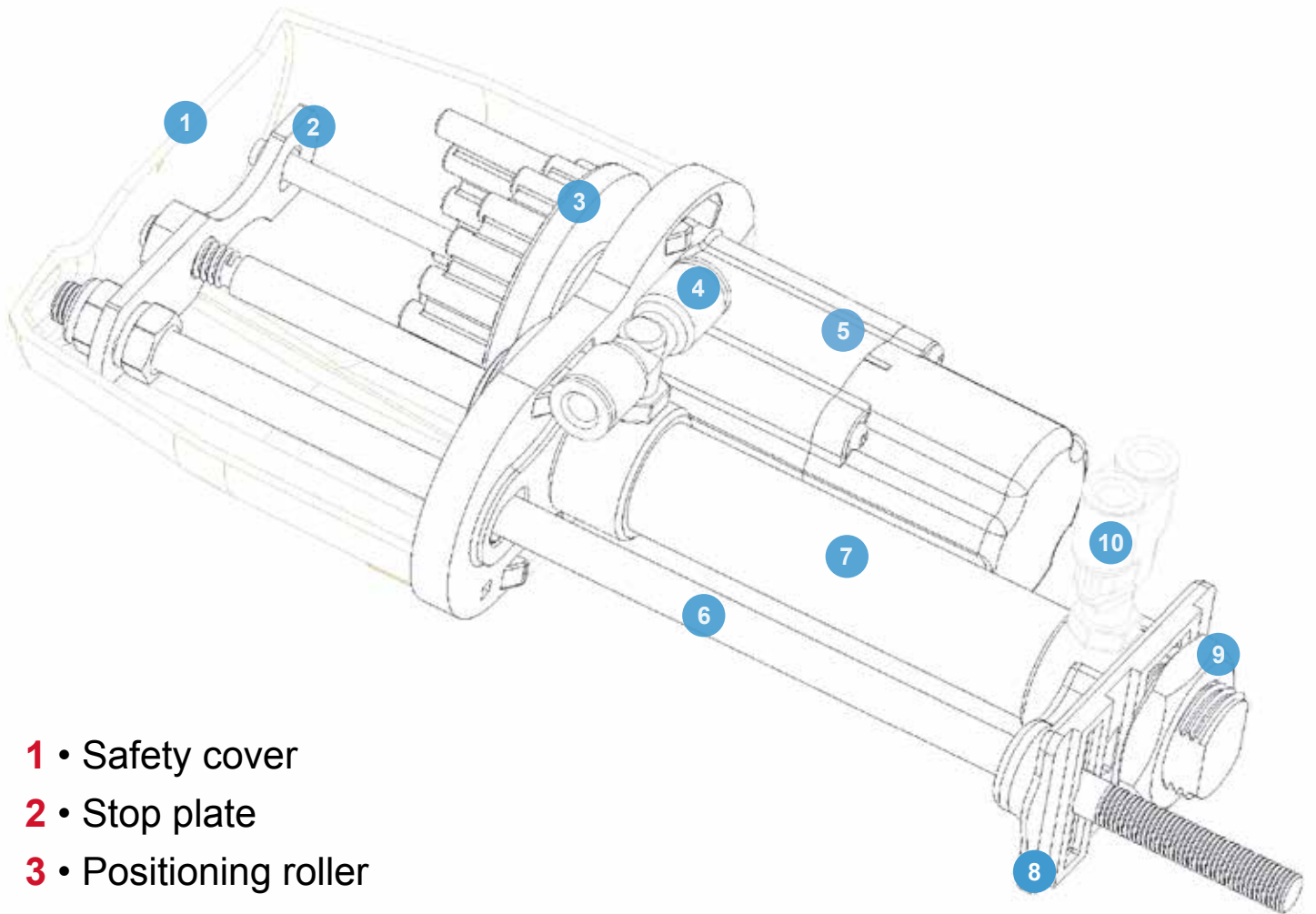

- 1 • Safety cover
- 2 • Stop plate
- 3 • Positioning roller
- 4 • Quick coupling "T" 1/8 GAS
- 5 • **SGA™** operating unit
- 6 • Rod clamp
- 7 • Mini-cylinder ISO 6432
- 8 • Mounting support
- 9 • M22 nut
- 10 • Quick coupling "Y" 1/8 GAS

## Part. S0837

### ■ Installation on compressed air conveyors

Each unit can be assembled on bored or slotted supporting profiles, based on the sizes suggested in the figures below.

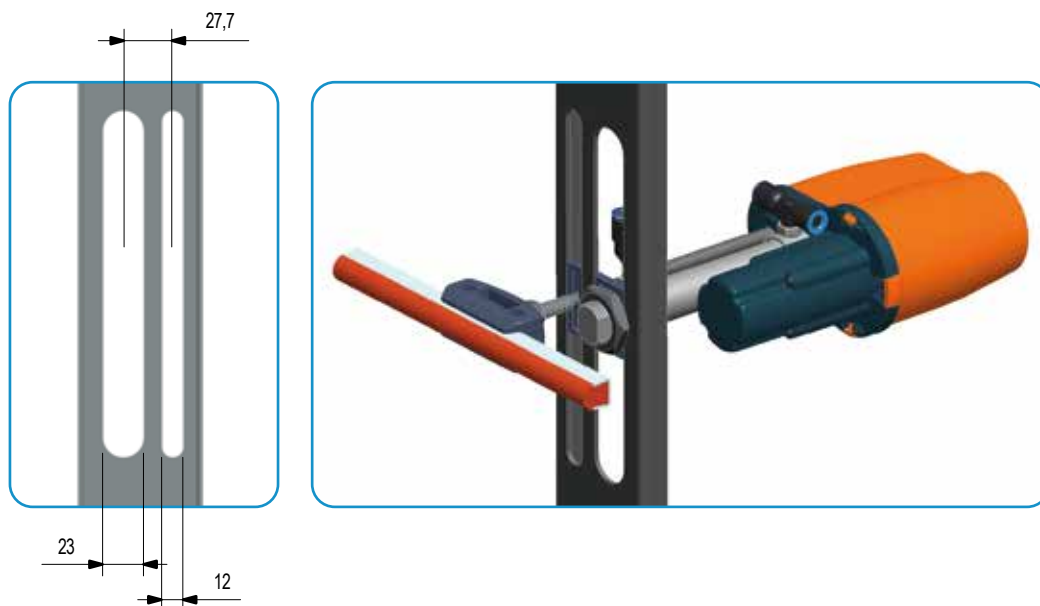

Example of installation of SGA™ system (Side Guide Adjustment™) on a compressed air conveyor. Working pressure  $\geq 4,5$  bar during adjustment.

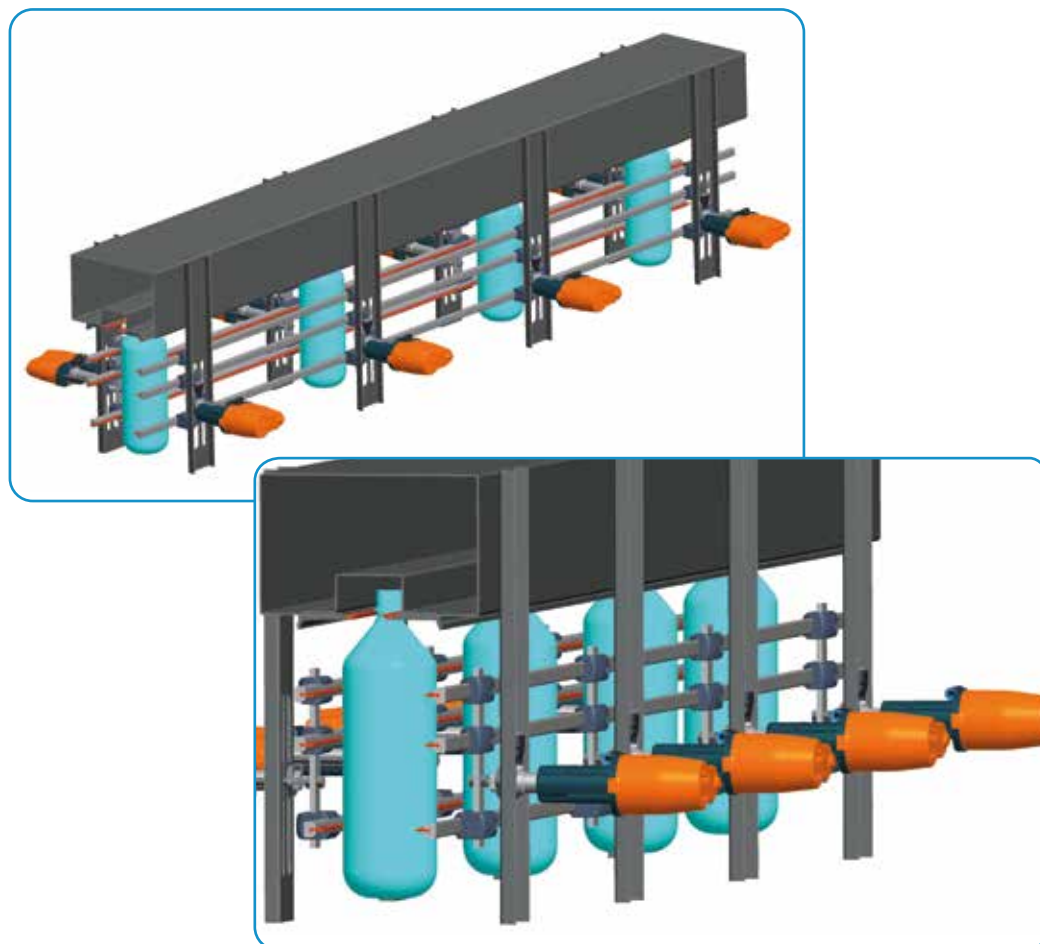

## ■ Installation on chain conveyors

Part. **S0837**

Each unit can be assembled on bored bars with holes according to the sizes indicated in the figures below.

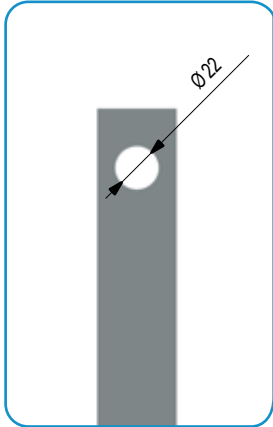

Example of installation of SGA™ system (Side Guide Adjustment™) on a chain conveyor.  
Working pressure  $\geq 4,5$  bar during adjustment.

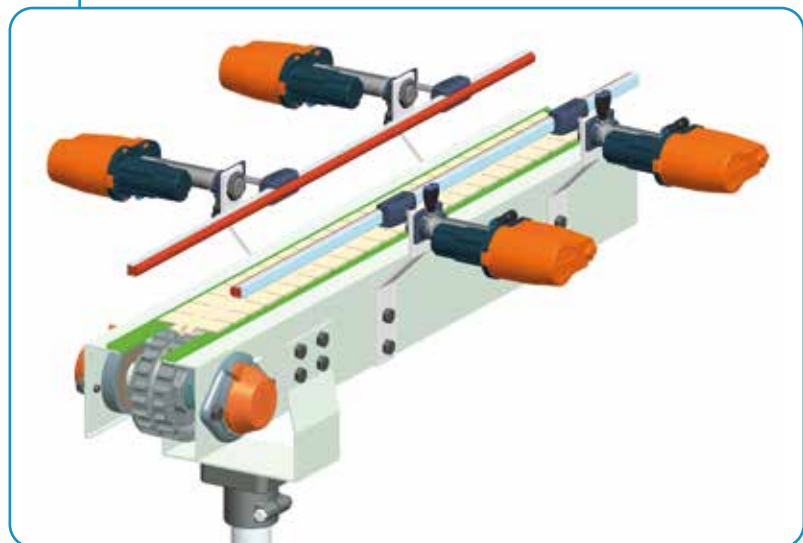

**Part. S0837**

**Technical information**

Example of side guide assembly.

**Clamp Part. 215**  
Guides Part. 223 -  
219 - 373 - 393  
596 - 308  
715 - 765  
767 - 768  
769 - 770

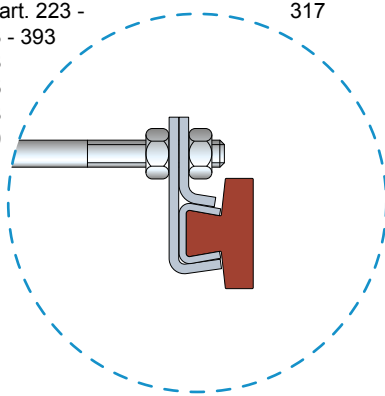

317

**Clamp Part. 159 - 437 - 451**

Round guides Dia. 8 - 10 - 12 - 14

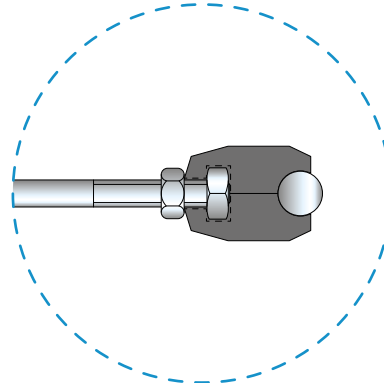

Leave min 20 mm for system movement

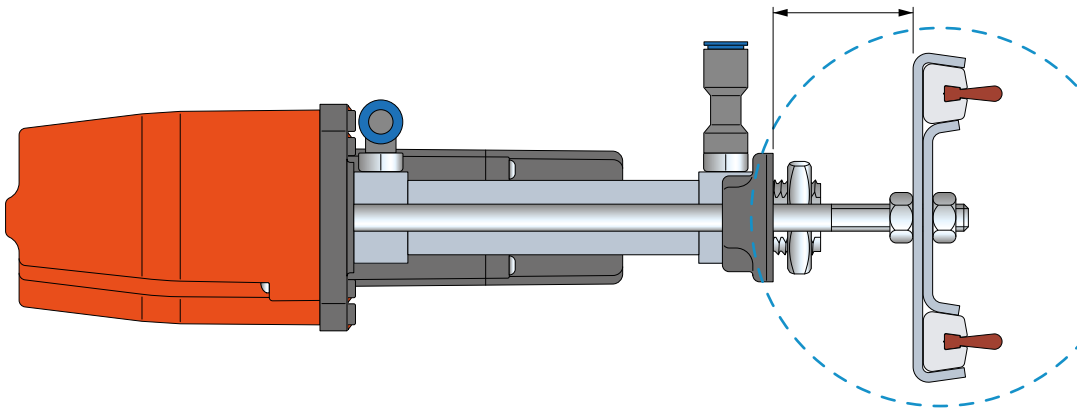

**Clamp Part. 217**

Guides Part.  
223 - 317  
219 - 373  
393 - 596  
308 - 715  
765 - 767  
768 - 769  
770

**Clamp Part. 211 - 446**

Guides Part. 223 - 317  
219 - 373 - 393  
596 - 308  
715 - 765  
767 - 768  
769 - 770

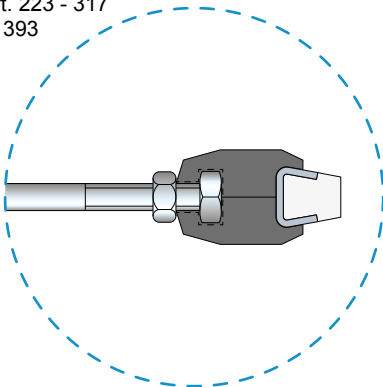

**M8 nut UNI 5589-65**

Guides Part. 756 - 757 - 856 - 868

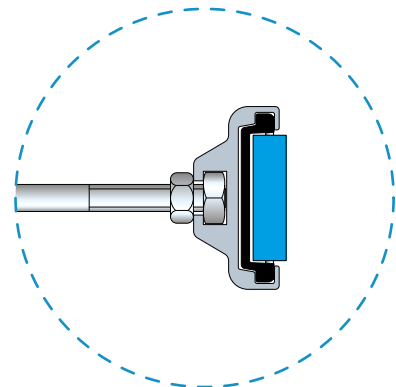

**M8 nut UNI 5589-65**

Guides Part. 346 - 832

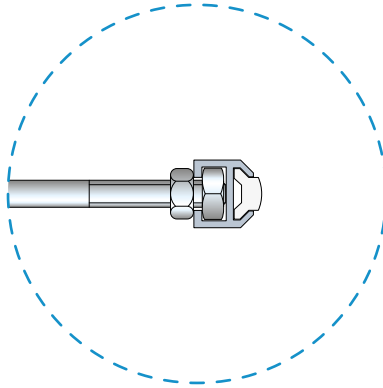

### Assembly drawing 1

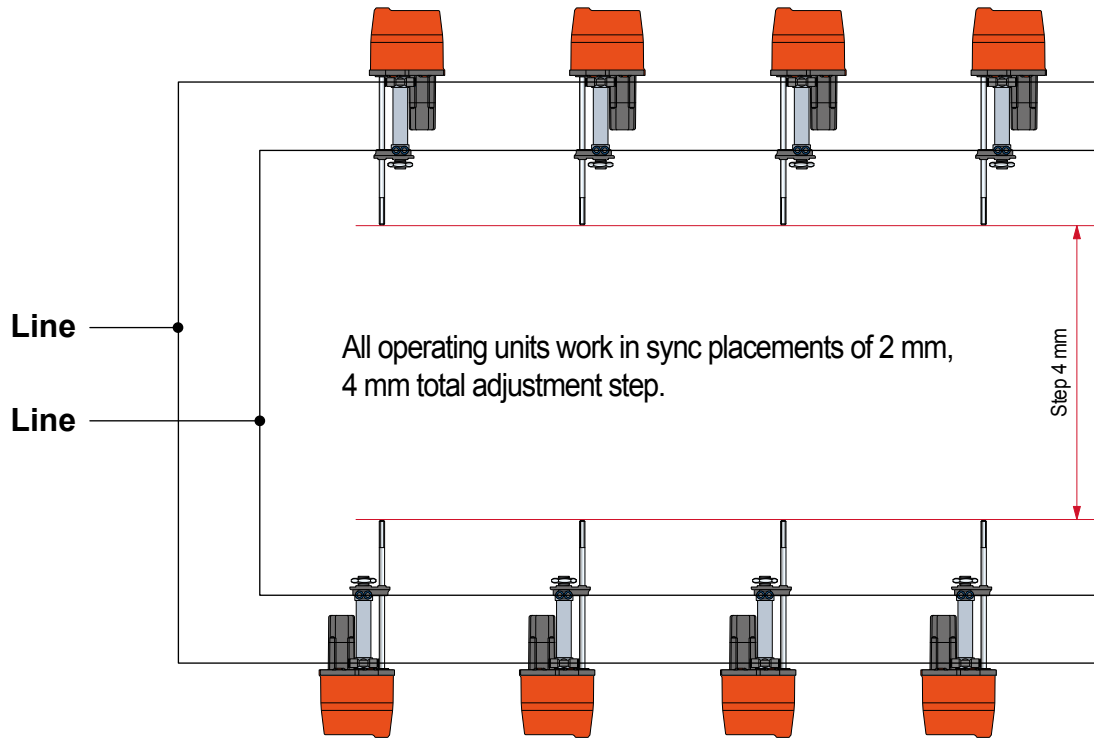

### Assembly drawing 2

