

Part. **S0733**

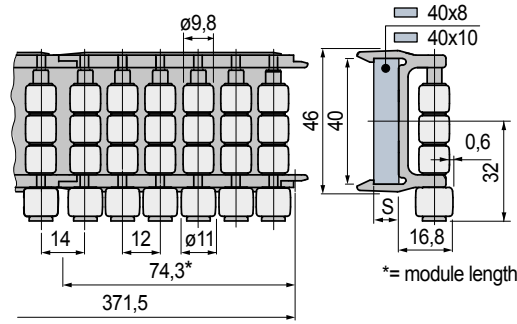

■ Roller side guide



Version	S mm	Code	Weight kg/m
For 40x8 plate	8	693512	0,61
For 40x10 plate	10	693522	

- Material: frame in acetal POM (black). Rollers in Rex-Hp™ (grey).
- Standard packaging: strands of 0,371 metres (5 modules).
- Packaging: 4,5 metres (12 strands).
- Accessories:
 - Metal profile 40x8 Part. S0537

Part. **S0721**



■ Centre roller guide

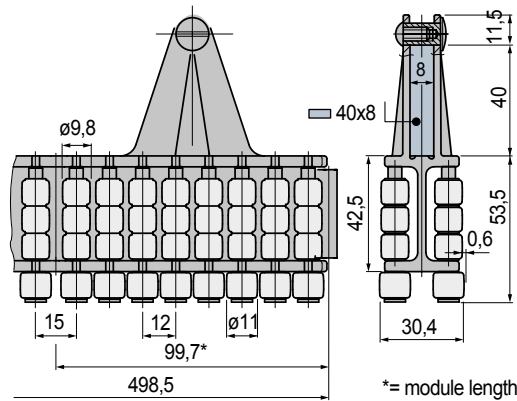

Version	Code	Weight kg
For 40x8 plate	688602	1,24

- Material: frame in acetal POM (black). Rollers in Rex-Hp™ (grey).
- Min. curvature radius: 335 mm.
- Standard packaging: strands of 0,498 metres (5 modules).
- Packaging: 4,5 metres (9 strands).
- Accessories:
 - Divider module Part. S0730
 - Metal profile 40x8 Part. S0537

• Use of Part.S0733 - S0721

Ideal for thin walled cans and delicate containers. The contact between can and rollers takes place near the can bottom where it is stronger.

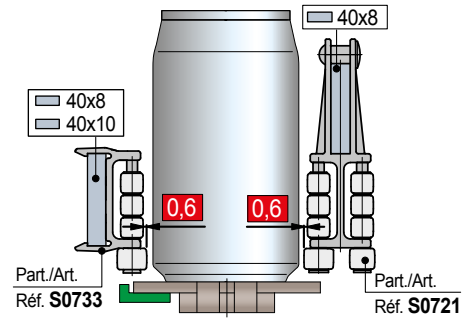

• Fixing of Part. S0733

Snap-on assembly / disassembly.

- Fixing with plate.

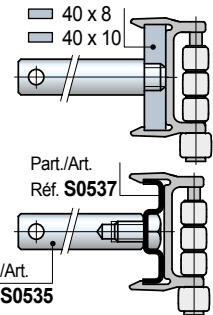

- Fixing with metal profile Part. S0537.

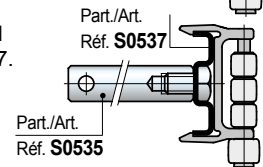

• Min. curvature radius Part. S0733

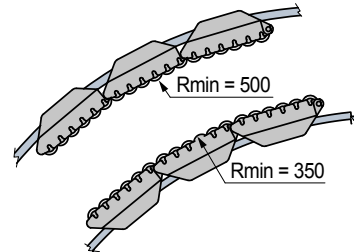

• Fixing of Part. S0721

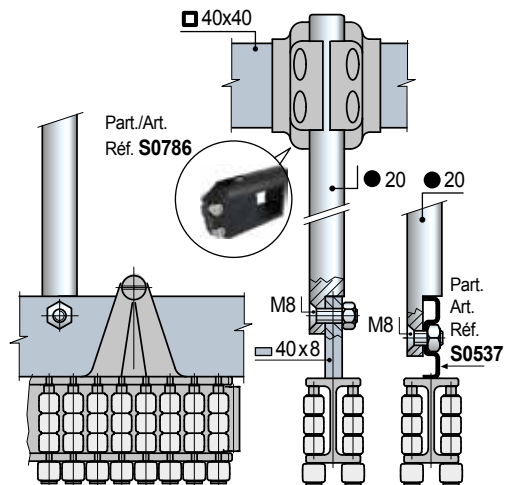

• Modular system Part. S0733 - S0721

The guide consists of modules with snap-on assembly.

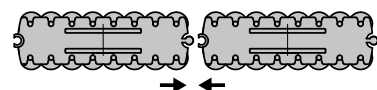

● Best Seller

● Standard

● On request: minimum quantity may apply. Consult our Customer Service for availability.

Item code for order = Part. + Code