

Part. **S0580**

Roller side guide

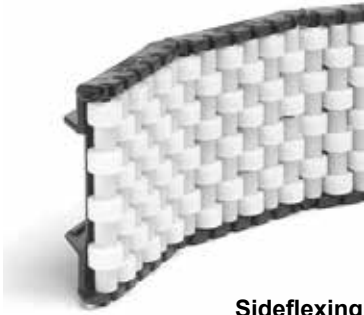

Sideflexing

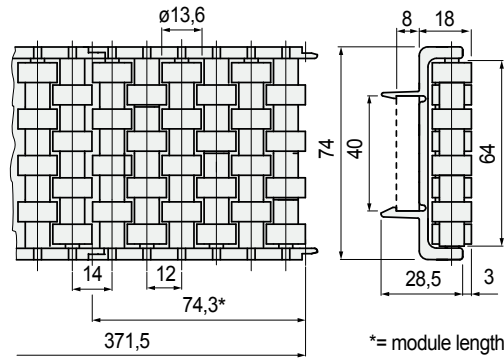

*= module length

Version	Code	Weight kg
For 40x8 plate	603292	0,99

- Material: frame in Acetal POM (black), rollers in Acetal POM (white).
- Standard packaging: strands of 0,371 metres (5 modules).
- Packaging: 4,5 metres (12 strands).
- Accessories:

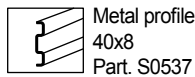

Part. **S0557**

Centre roller guide



Sideflexing

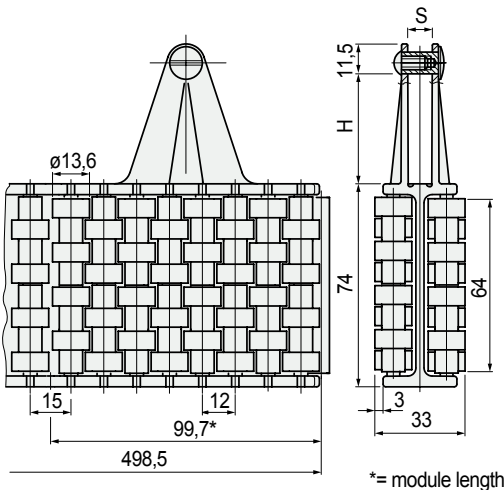

*= module length

Version	H mm	S mm	Code	Weight kg/m
For 30x6 plate	30	6	603472	1,96
For 40x8 plate	40	8	603482	

- Can be used in combination with Part. S0580.
- Material: frame in Acetal POM (black), rollers in Acetal POM (white).
- Min. curvature radius: 335 mm.
- Standard packaging: strands of 0,498 metres (5 modules).
- Packaging: 4,5 metres (9 strands).
- Accessories:

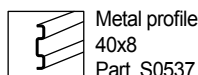

- Use of Part. S0580 - S0557
For medium strength containers (tin cans, glass, strong aluminium cans).

- Fixing of Part. S0580
Snap-on assembly / disassembly

- Fixing with plate.

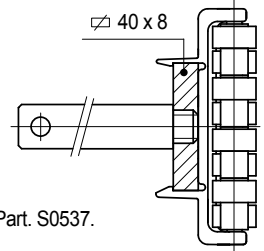

- Fixing with metal profile Part. S0537.

Part./Art./Réf. **S0537** (40x8)

Part./Art. Réf. **S0535**

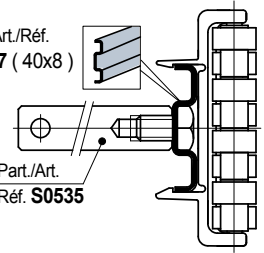

- Min. curvature radius Part. S0580

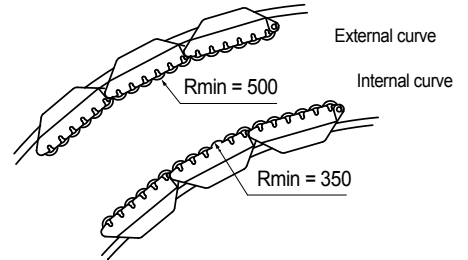

- Fixing of Part. S0557
Assembly / disassembly.

- Fixing with plate.

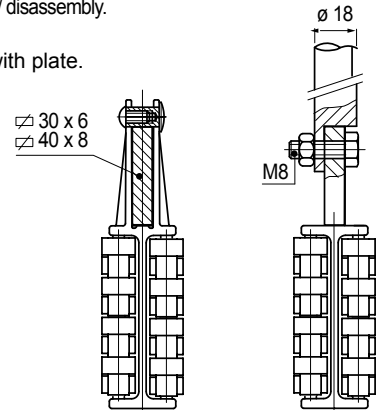

- Fixing with metal profile Part. S0537.

Part./Art./Réf. **S0537**(40x8)

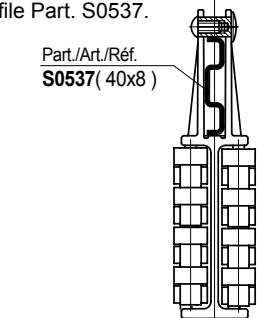

- Modular system Part. S0580 - S0557

The guide consists of modules with snap-on assembly.

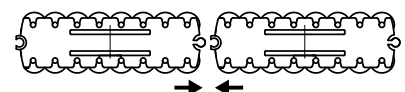

Best Seller

Standard

On request: minimum quantity may apply. Consult our Customer Service for availability.

Item code for order = Part. + Code