

Part. S0858

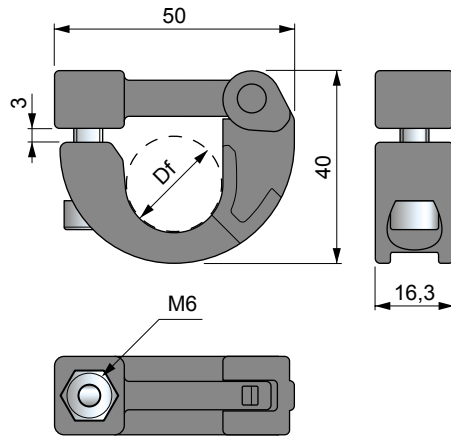

Hinge Joint



Bore dia. mm	Code	Weight kg
ø 20	645493	0,03

- Use: easy assembly of wear strips on tubes rods dia. 20 mm.
- Material: clamp in reinforced polyamide PA FV (black). Bolts and nuts in austenitic stainless steel.
- Packaging: 50 pieces.

Part. S0559



Connecting block

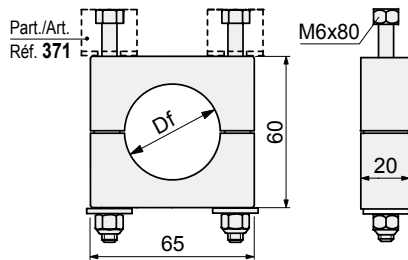

Bore dia. mm	Code
ø 38	696161

- Use: easy assembly of wear strips on tube dia. 38 mm.
- Material: clamp in reinforced polyamide PA FV (black). Bolts and nuts in austenitic stainless steel. Self-locking nuts.
- Packaging: 50 pieces.

Use of Part S0858

Assembly the chain guide profiles Part. S0366 - S0367 - S0368 on rods dia. 20 mm.



No more drilling holes to assemble the profile, possibility to easily adjust the position of the guide, standardization of the 20 mm rod already used for the chain return section (with rollers).



Assembly of Part. S0559

Part. S0371 (M6 version) shall be used to assemble wear strips on Part. S0559.

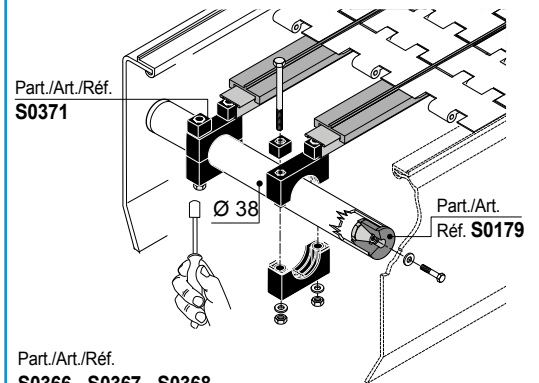

Part./Art./Réf.
S0366 - S0367 - S0368

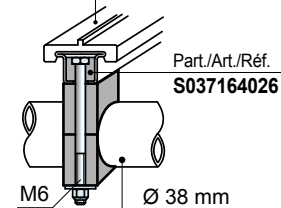

● Best Seller

● Standard

● On request: minimum quantity may apply. Consult our Customer Service for availability.

Item code for order = Part. + Code